

# FS-250 引擎式硬管割草機

傳動機構  
Gear Head

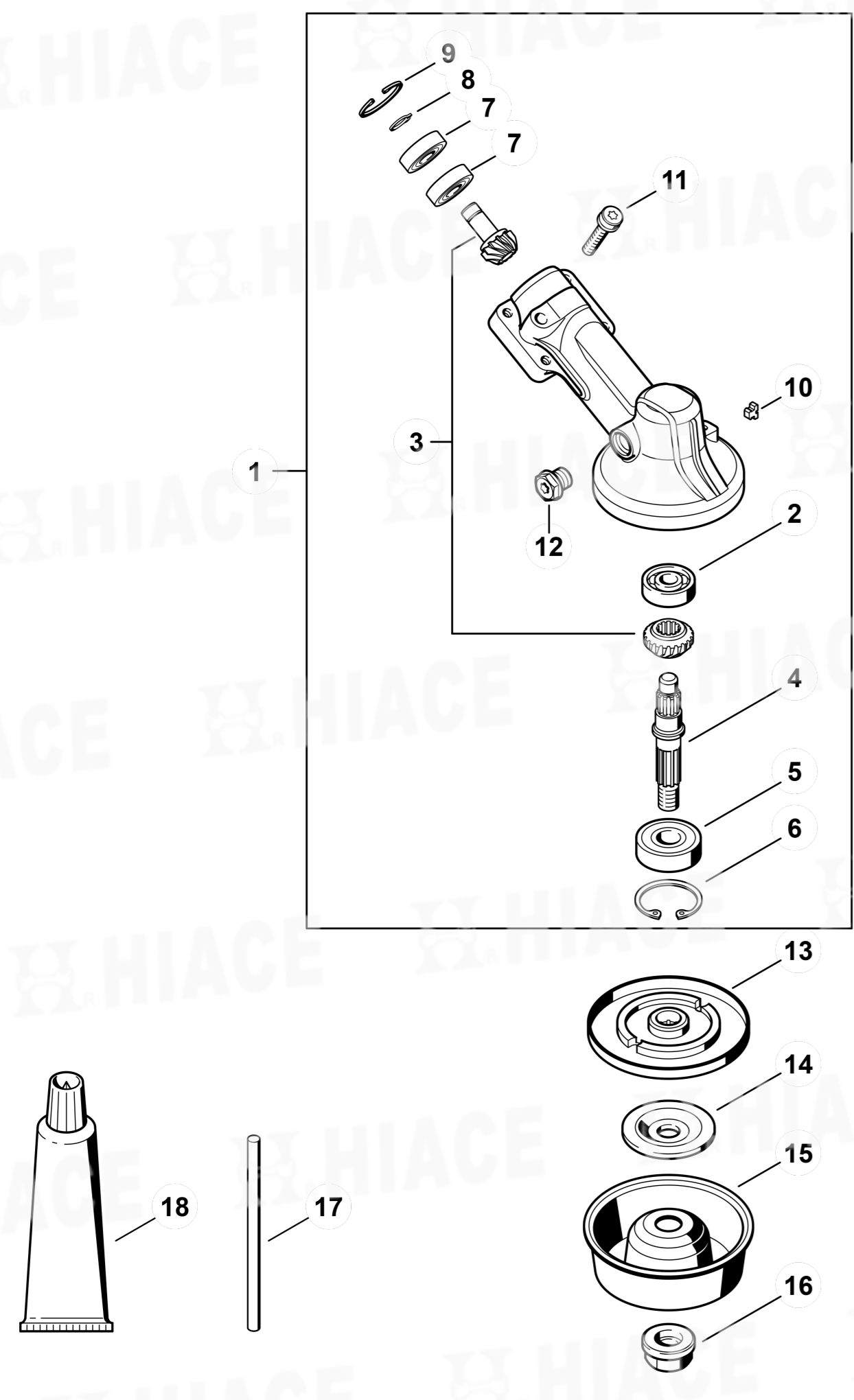

曲軸箱、汽缸  
Crankcase, Cylinder

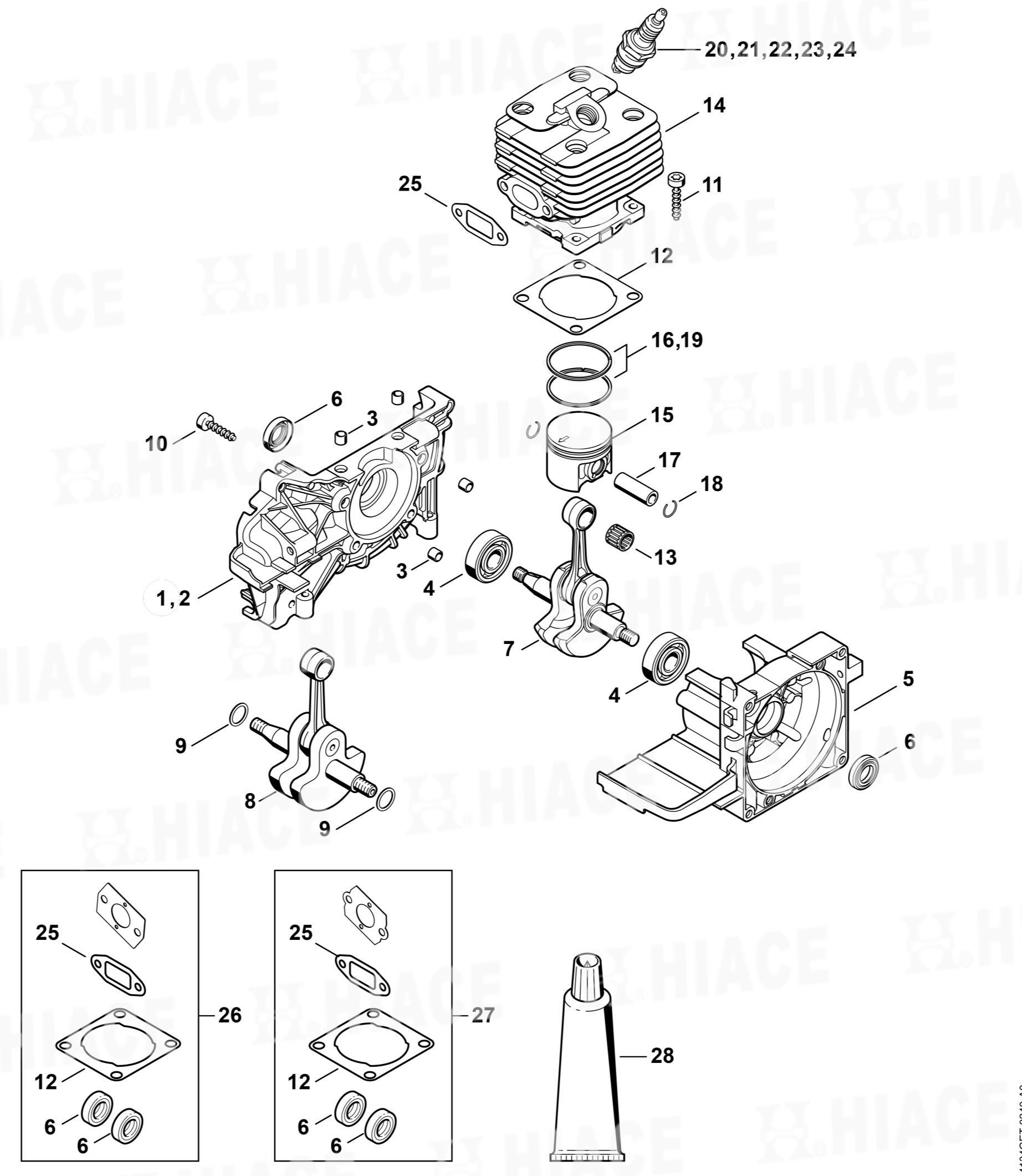

啟動裝置、點火系統  
Rewind starter, Ignition system

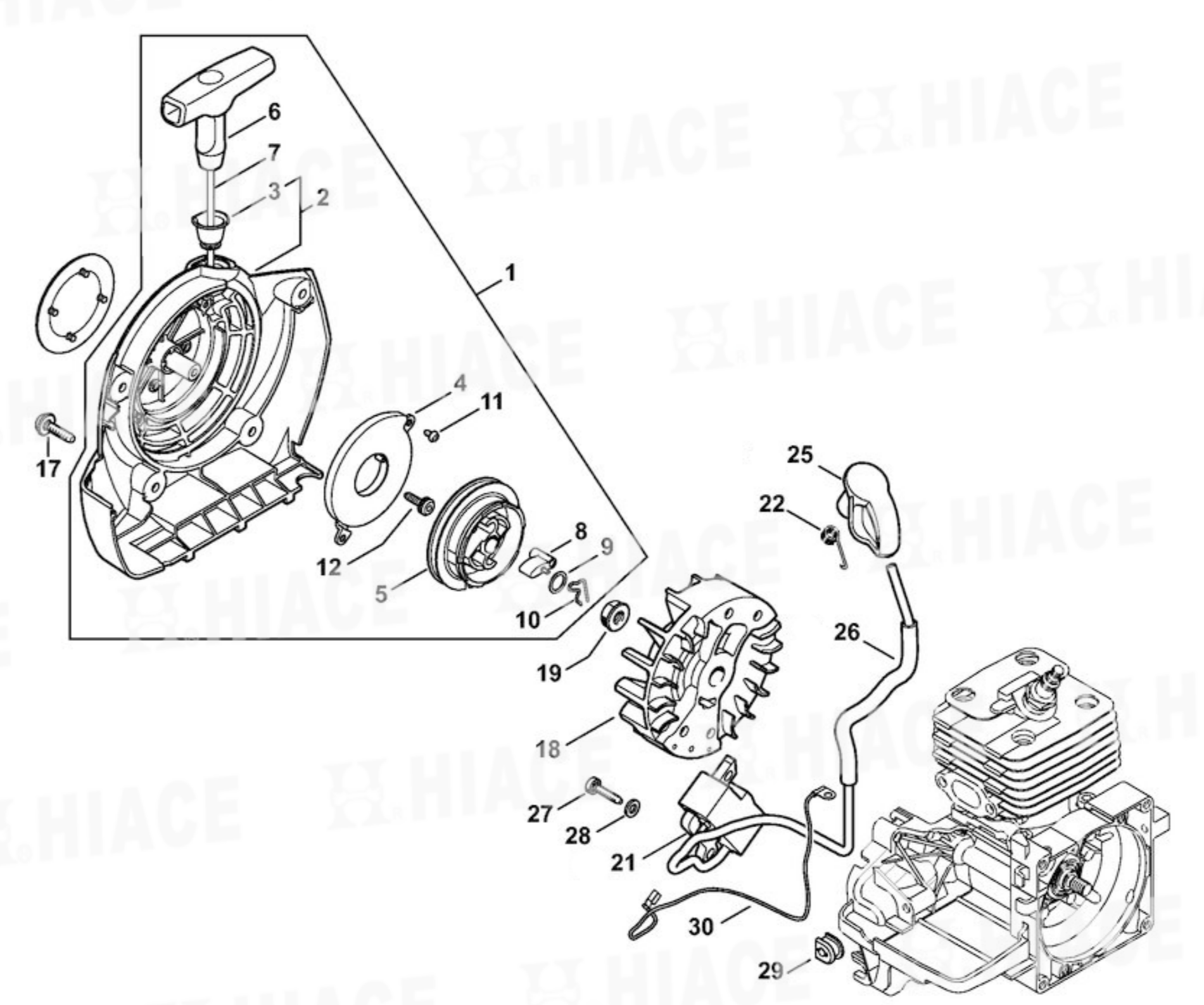

啟動裝置、點火系統  
Rewind starter, Ignition system  
809 249 646

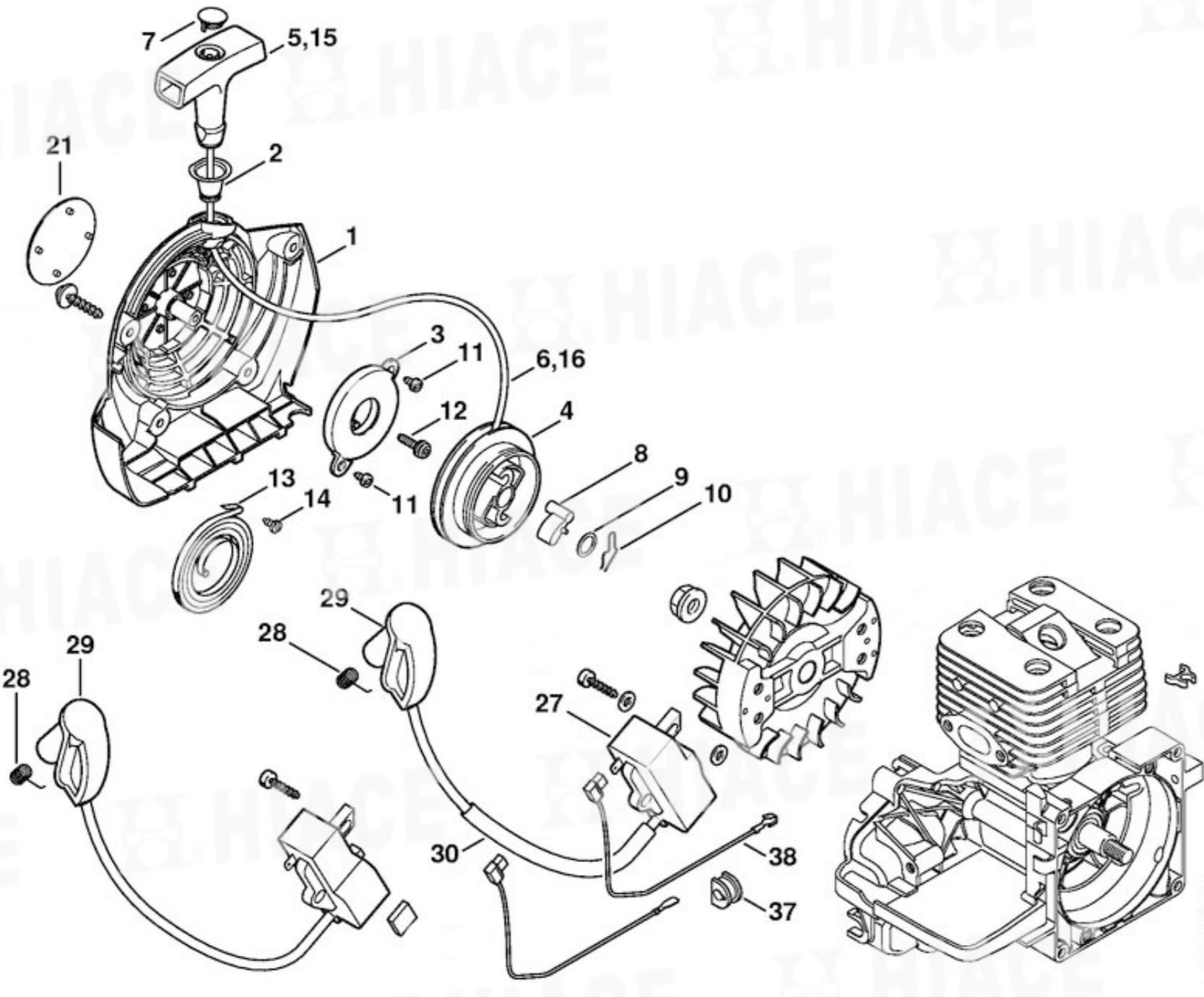

消音器、機罩、燃油箱  
Muffler, Shroud, Fuel tank

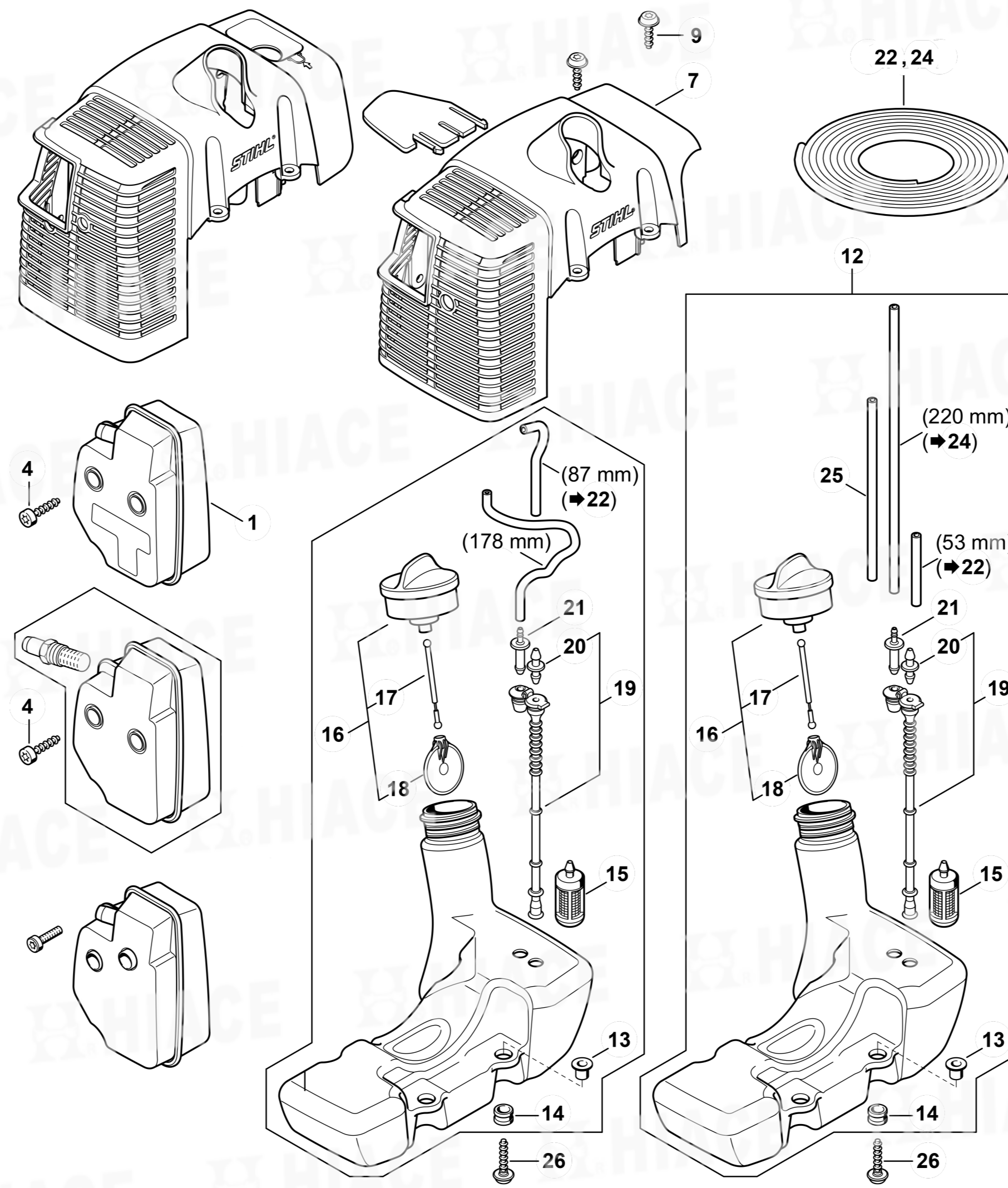

消音器、機罩、燃油箱  
Muffler, Shroud, Fuel tank  
809 249 646

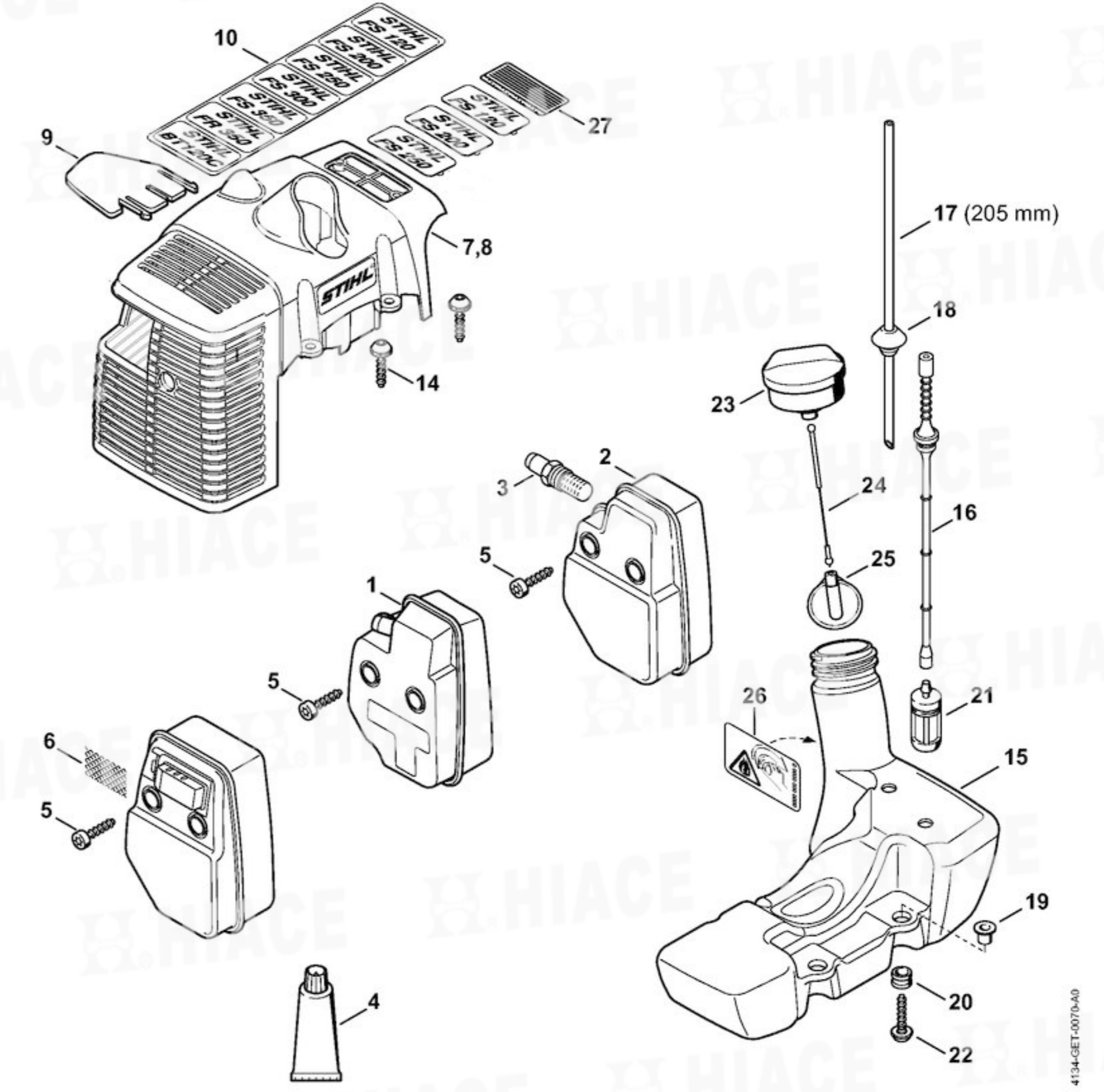

化油器外罩、空氣過濾器  
Carburetor housing, Air filter

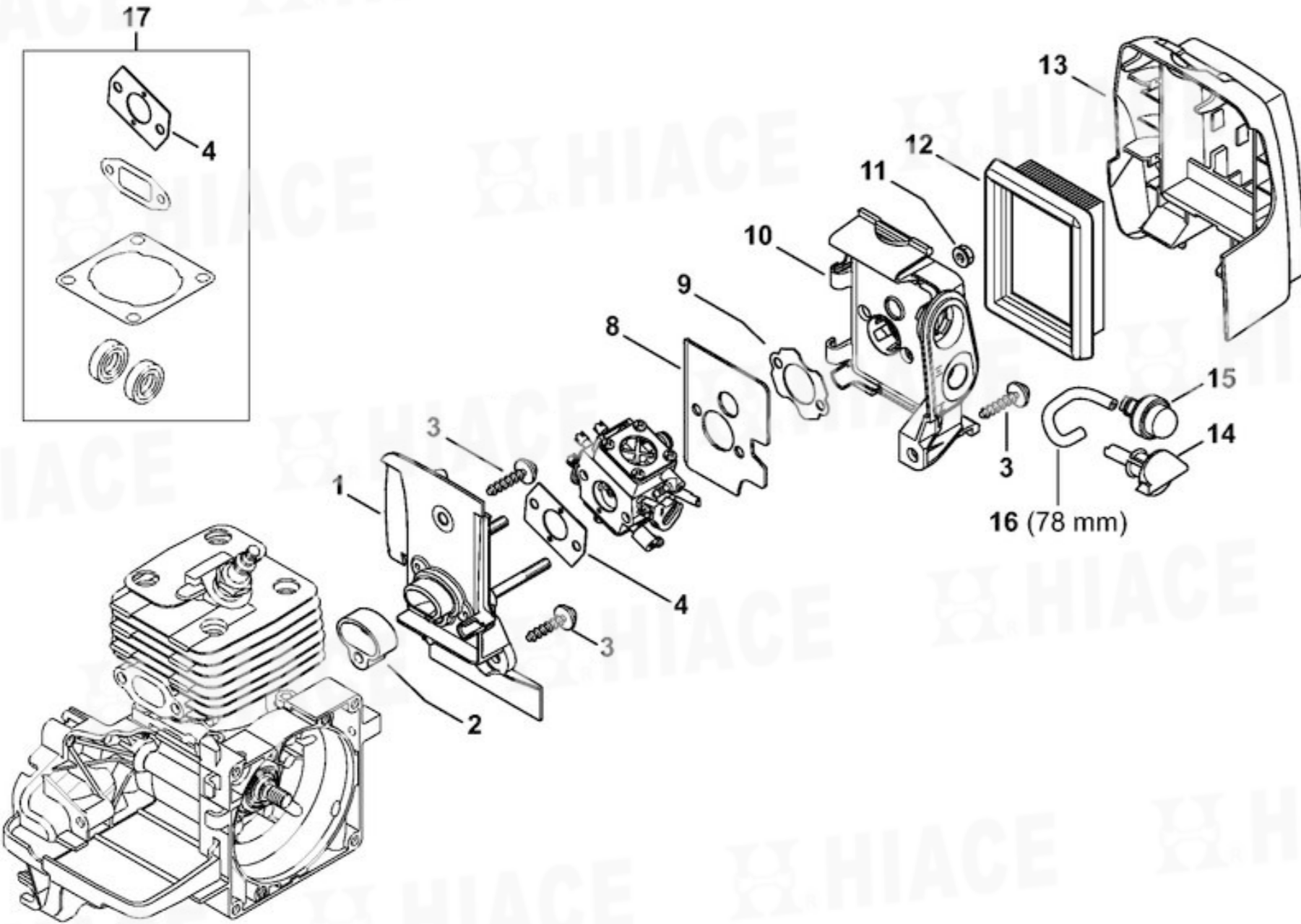

化油器外罩、空氣過濾器  
Carburetor housing, Air filter  
809 249 646

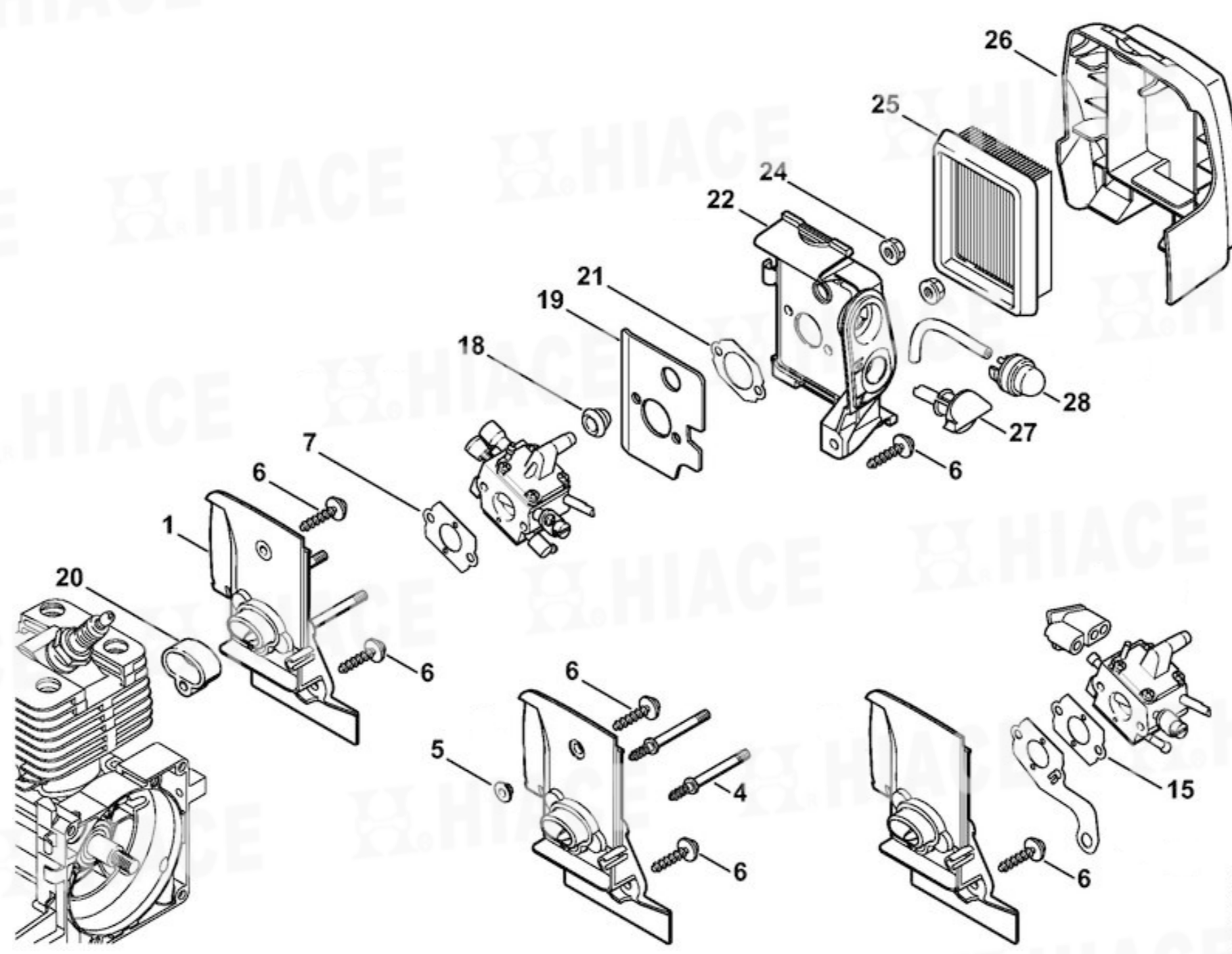

化油器  
Carburetor  
413/21、4134/22、4134/23

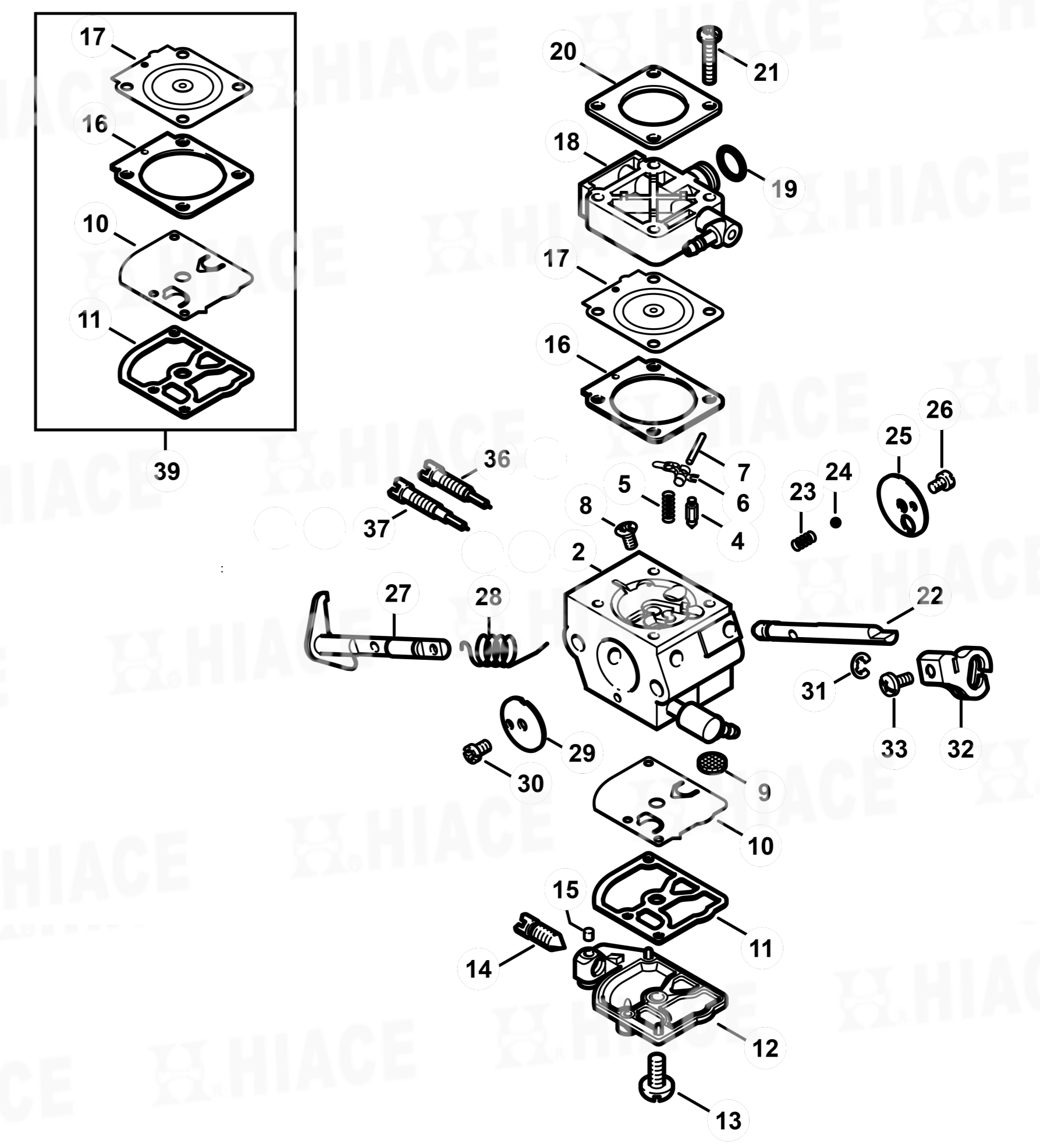

化油器  
Carburetor  
4134/13、4134/14、4134/15

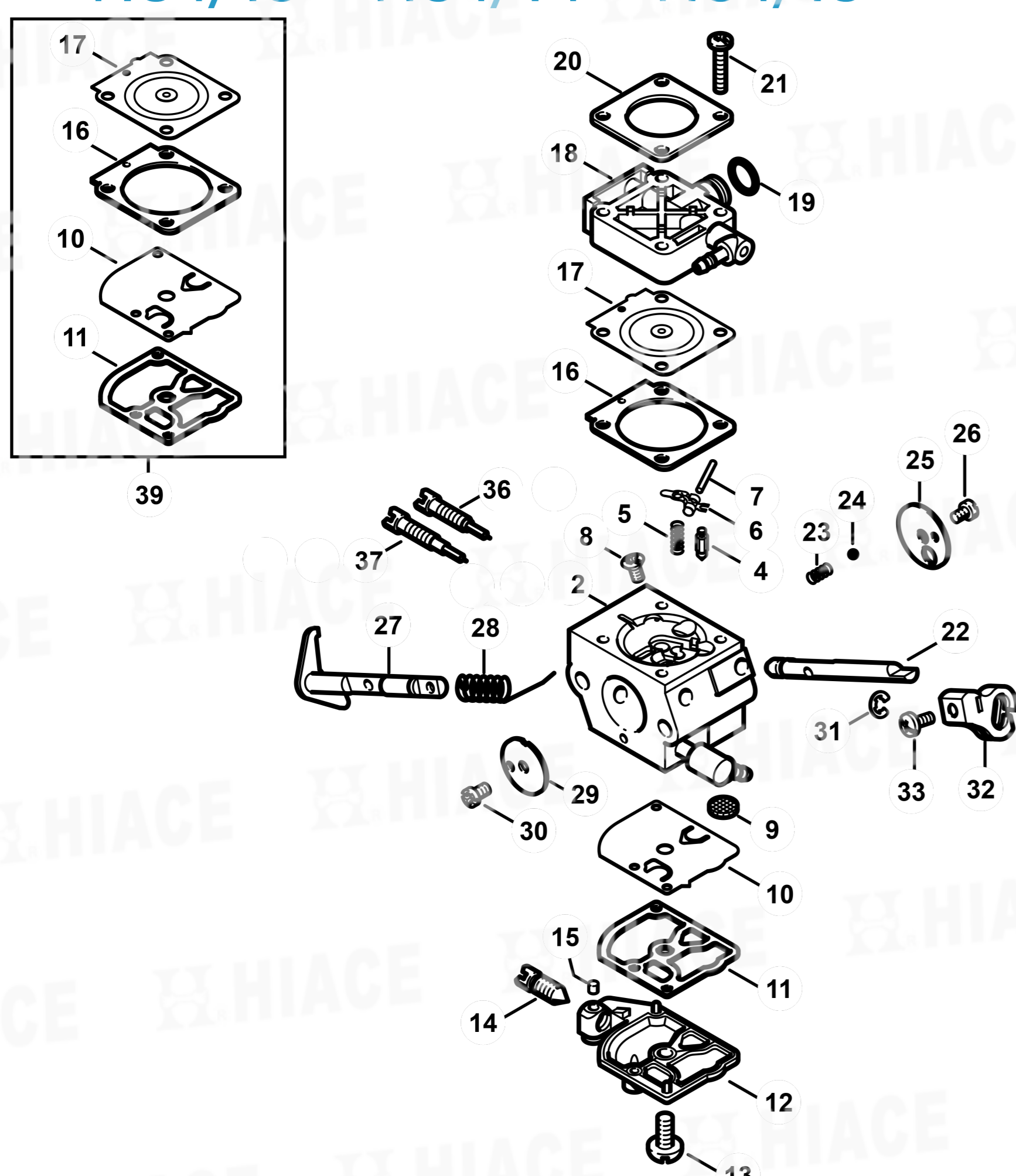

化油器  
Carburetor  
C1Q-S161、-S162、-S163、-S164、  
-S82、-S83、-S138、-S139

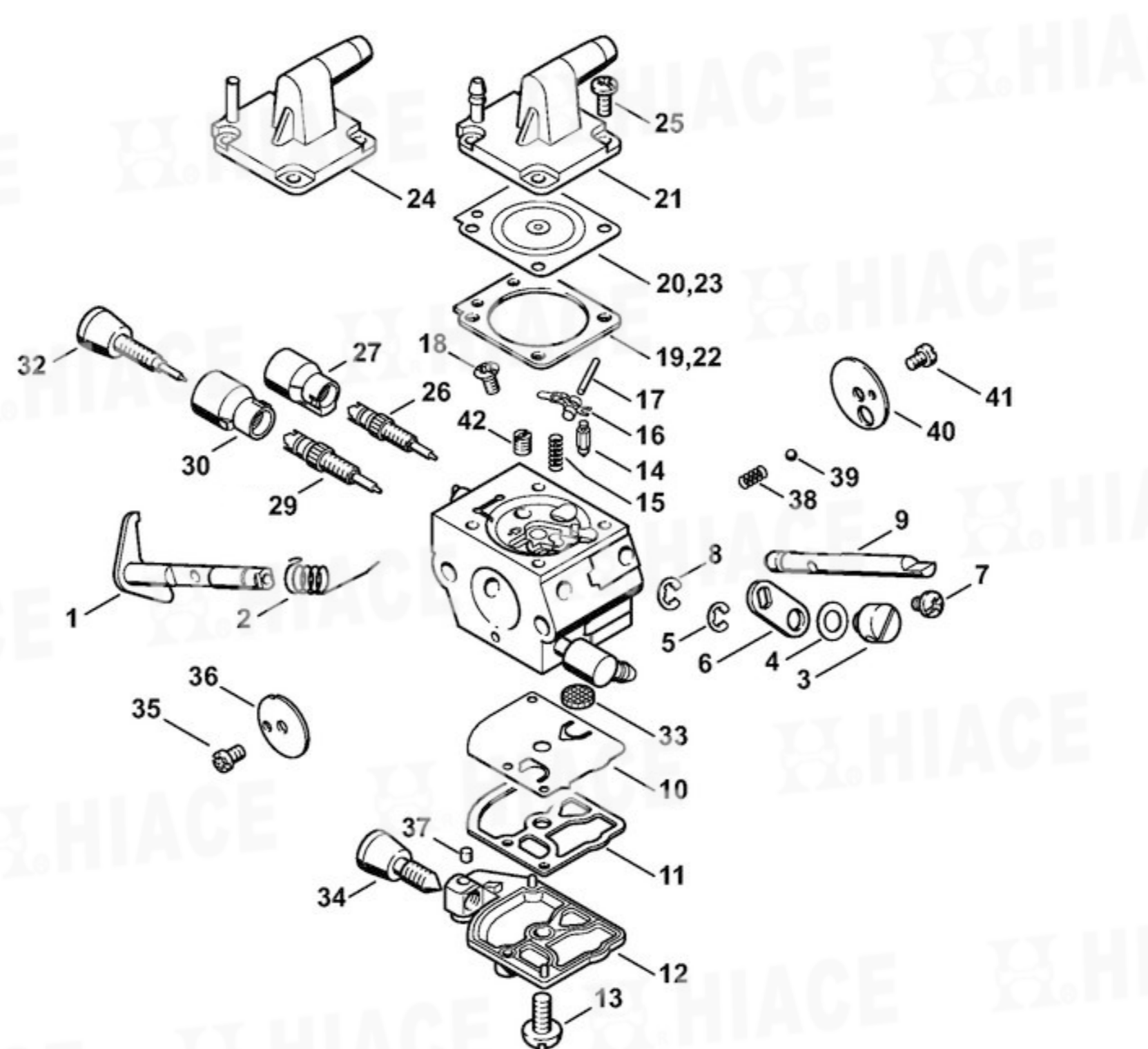

化油器  
Carburetor  
C1Q-S35(19.98)

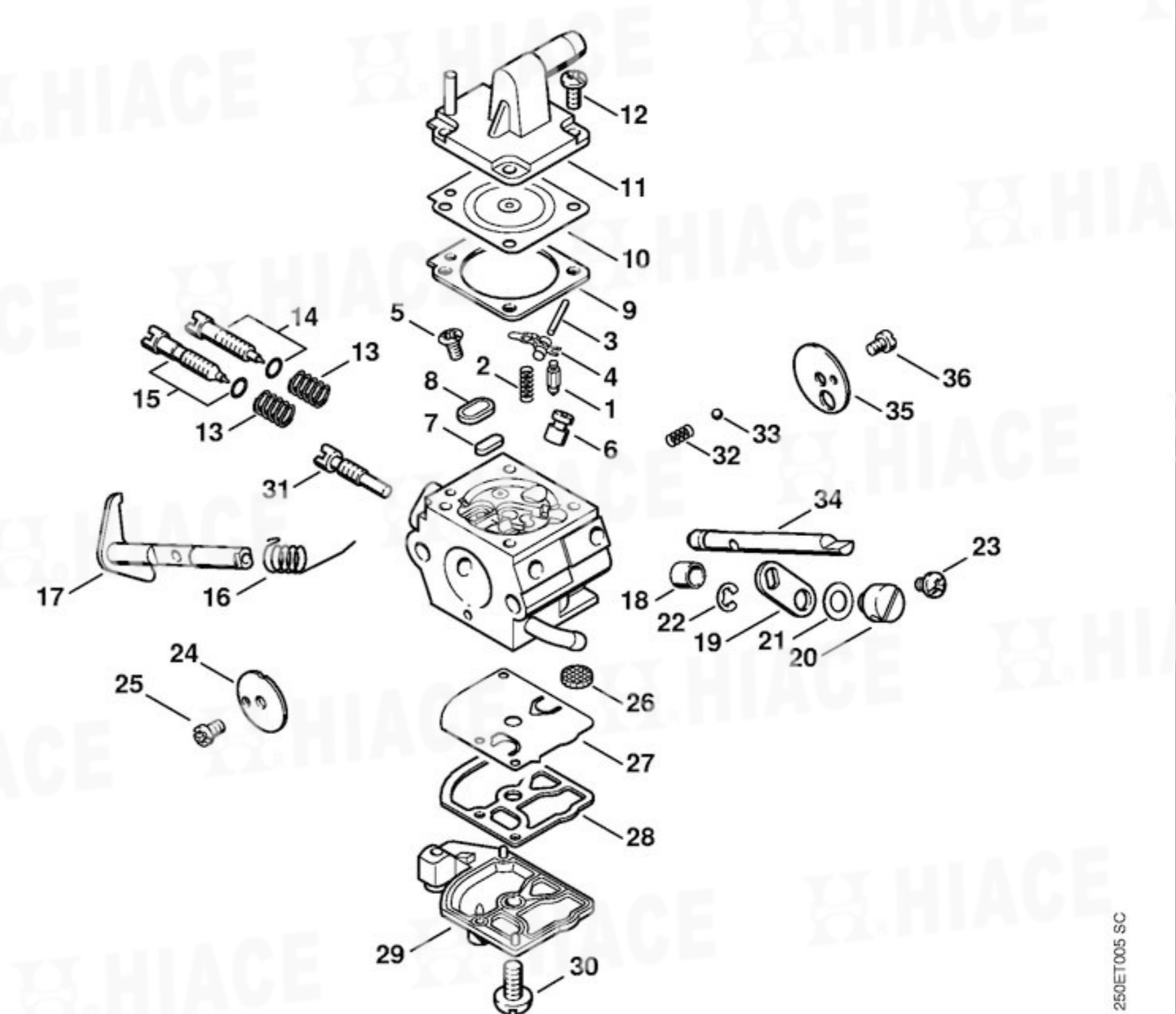

# FS-250 引擎式硬管割草機

離合器外罩  
Clutch housing

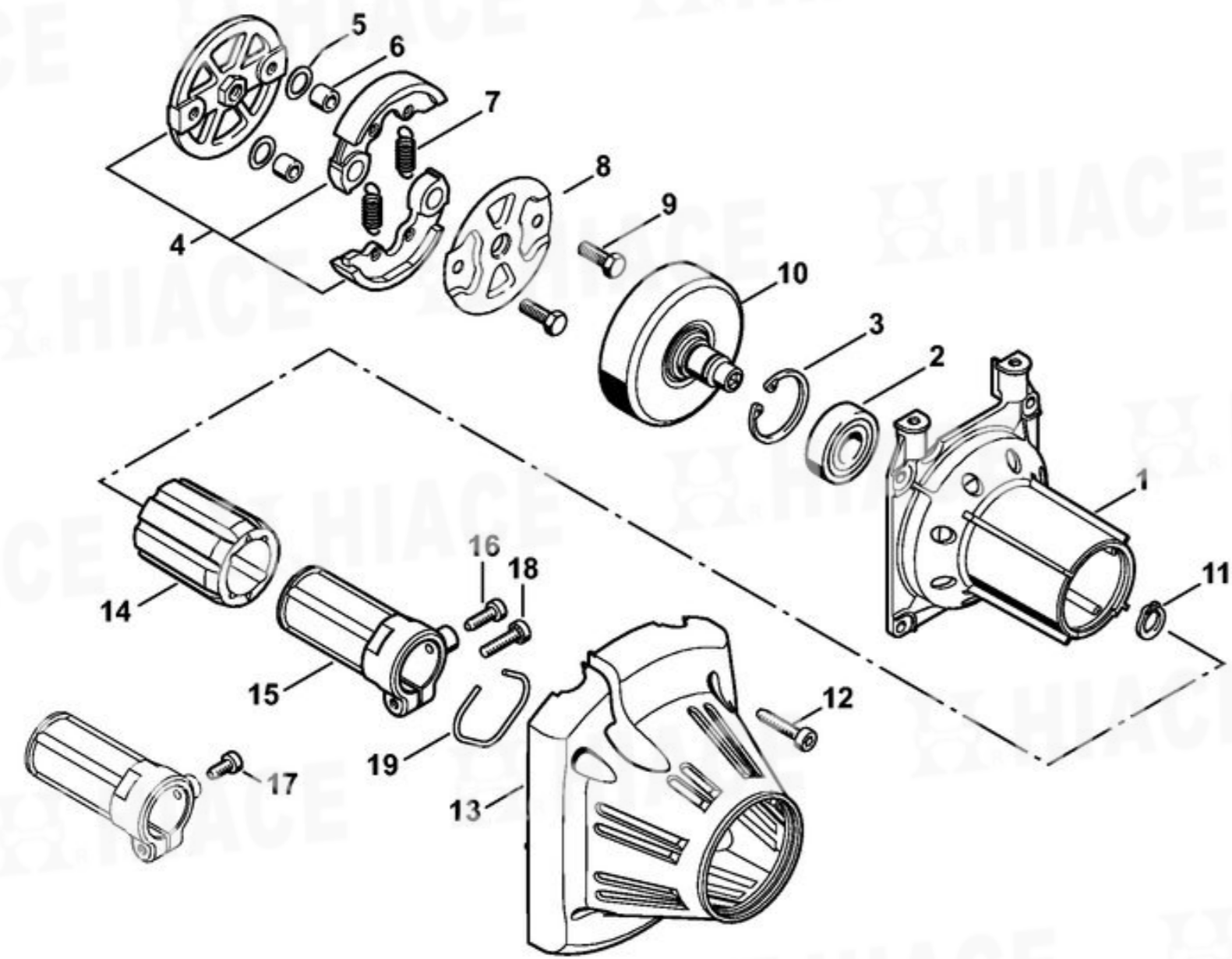

4134CE/0010040

雙手把手桿、控制把手  
Two-handed handle bar, Control handle

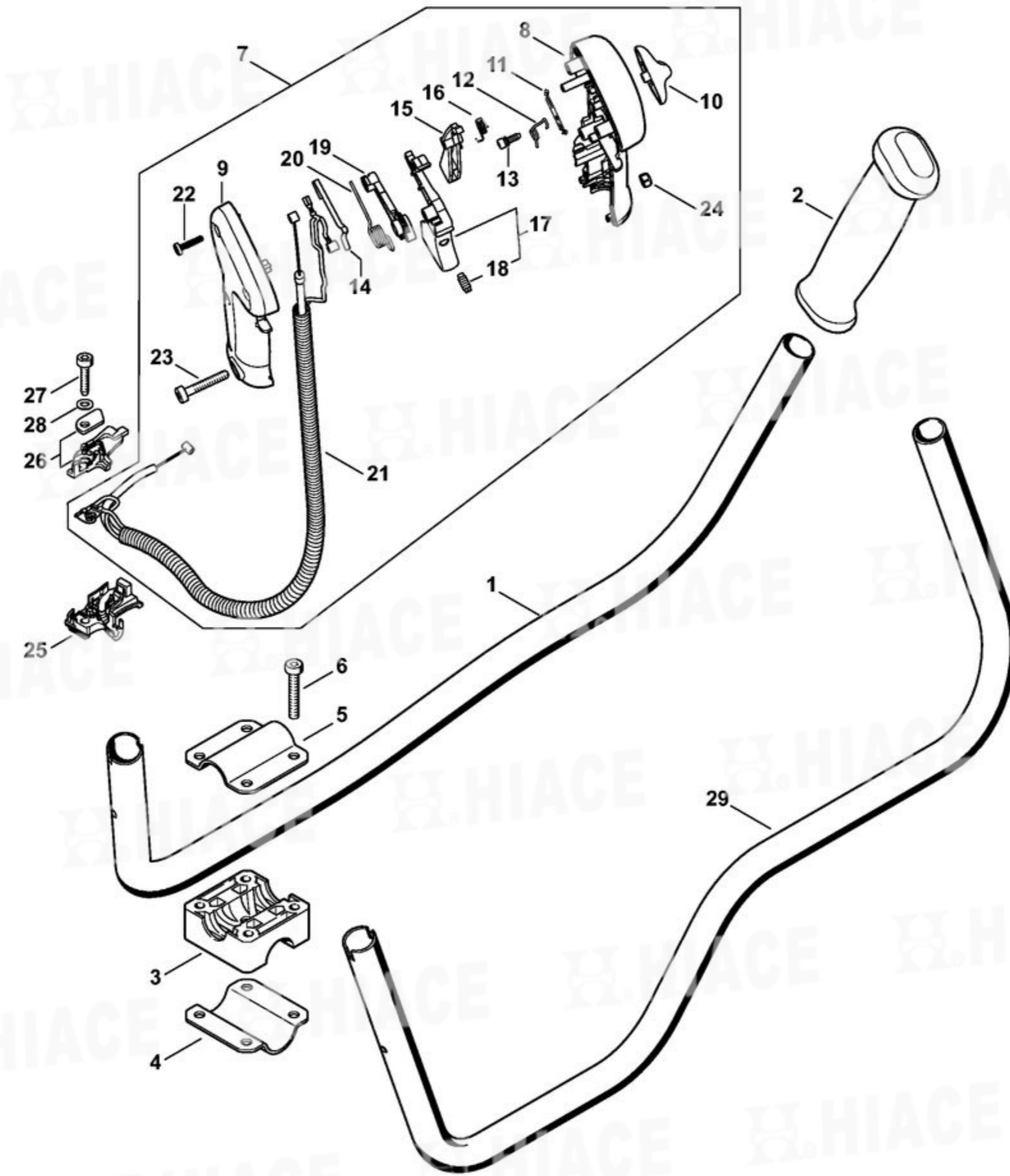

4134CE/0011500

雙手柄  
Bike handle

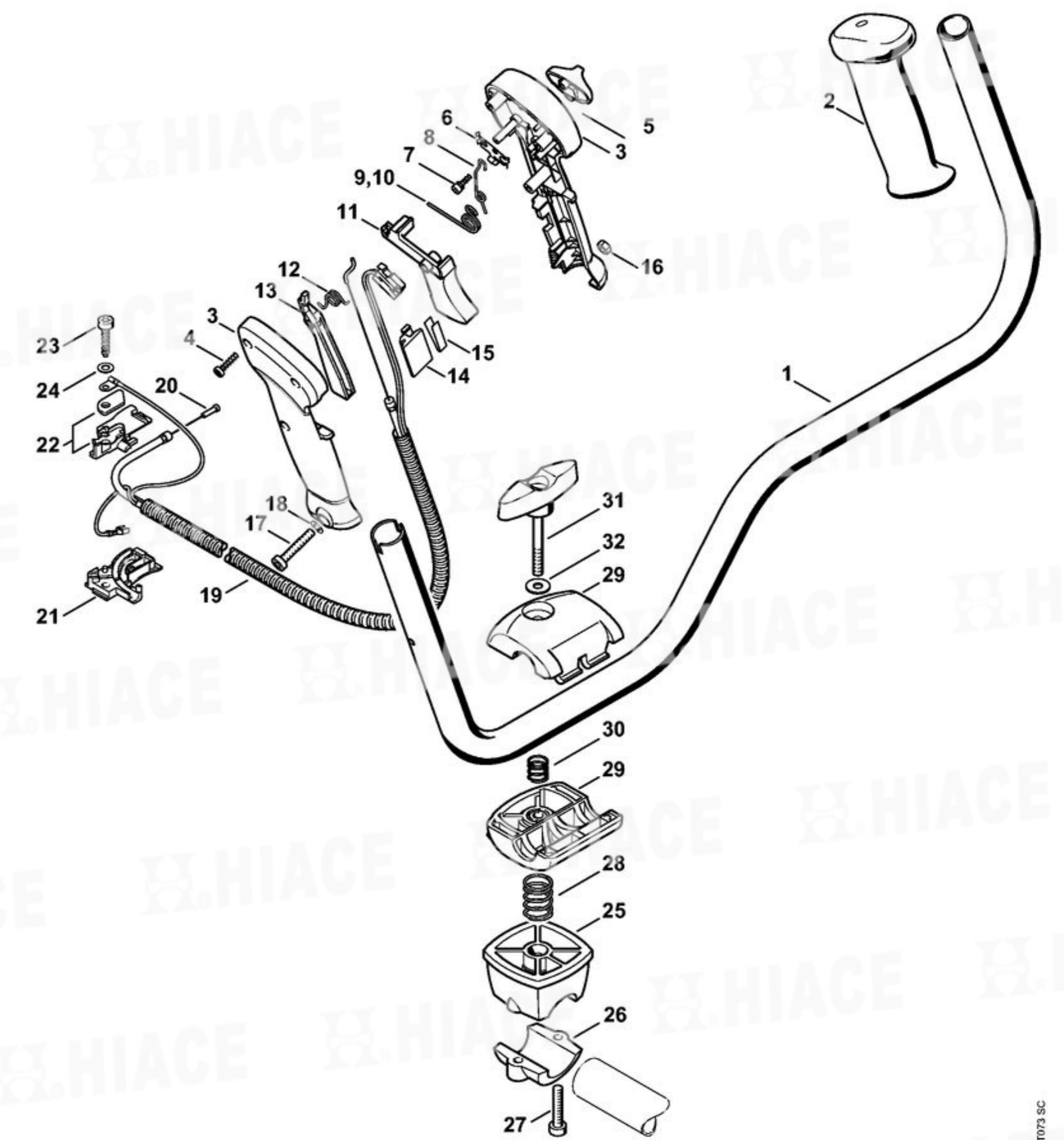

2010703.00

傳動桿組件  
Drive tube assembly

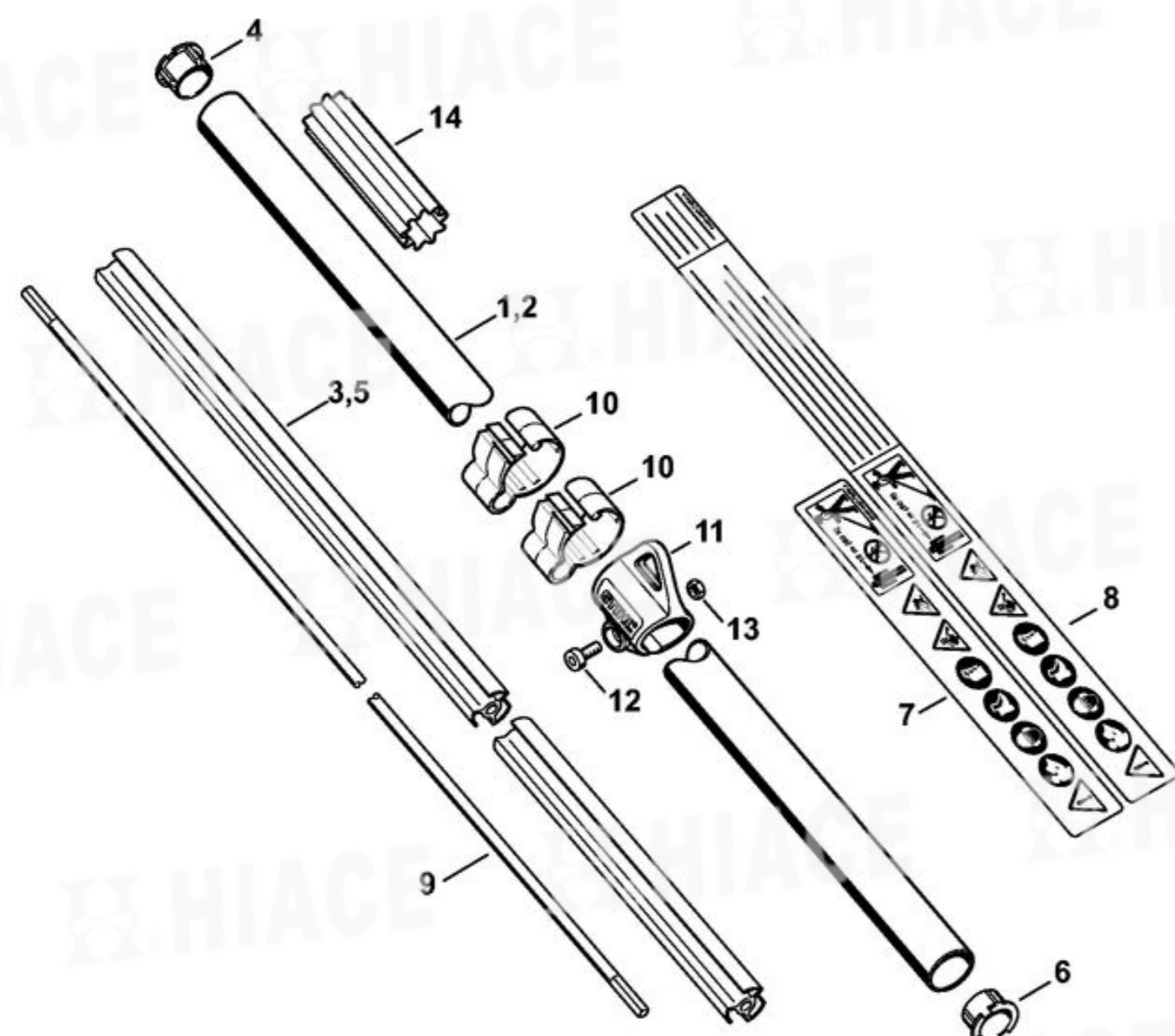

4134CE/0010040

防護罩  
Deflector

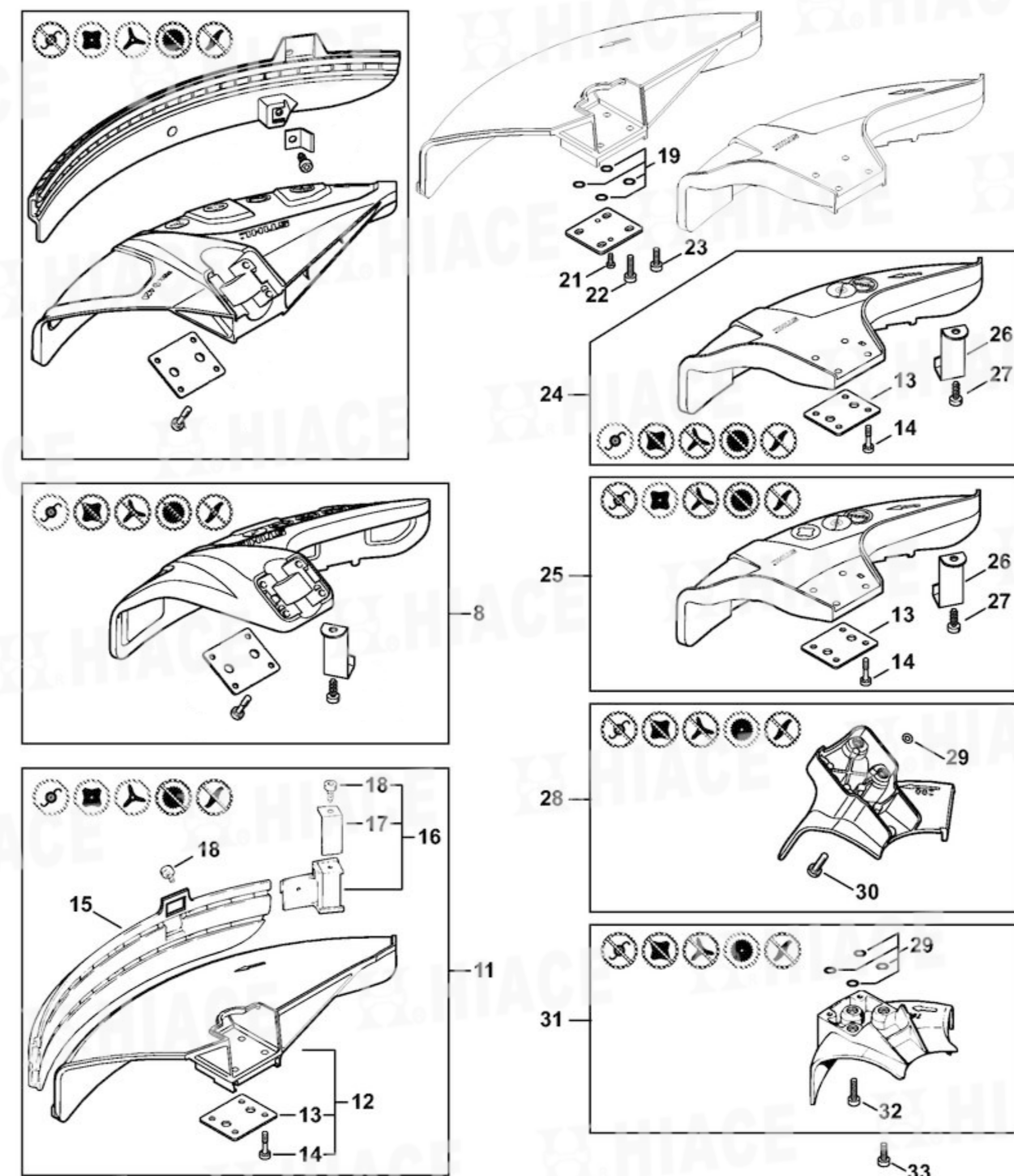

4134CE/0010040